

# ConvertCoal, Inc.

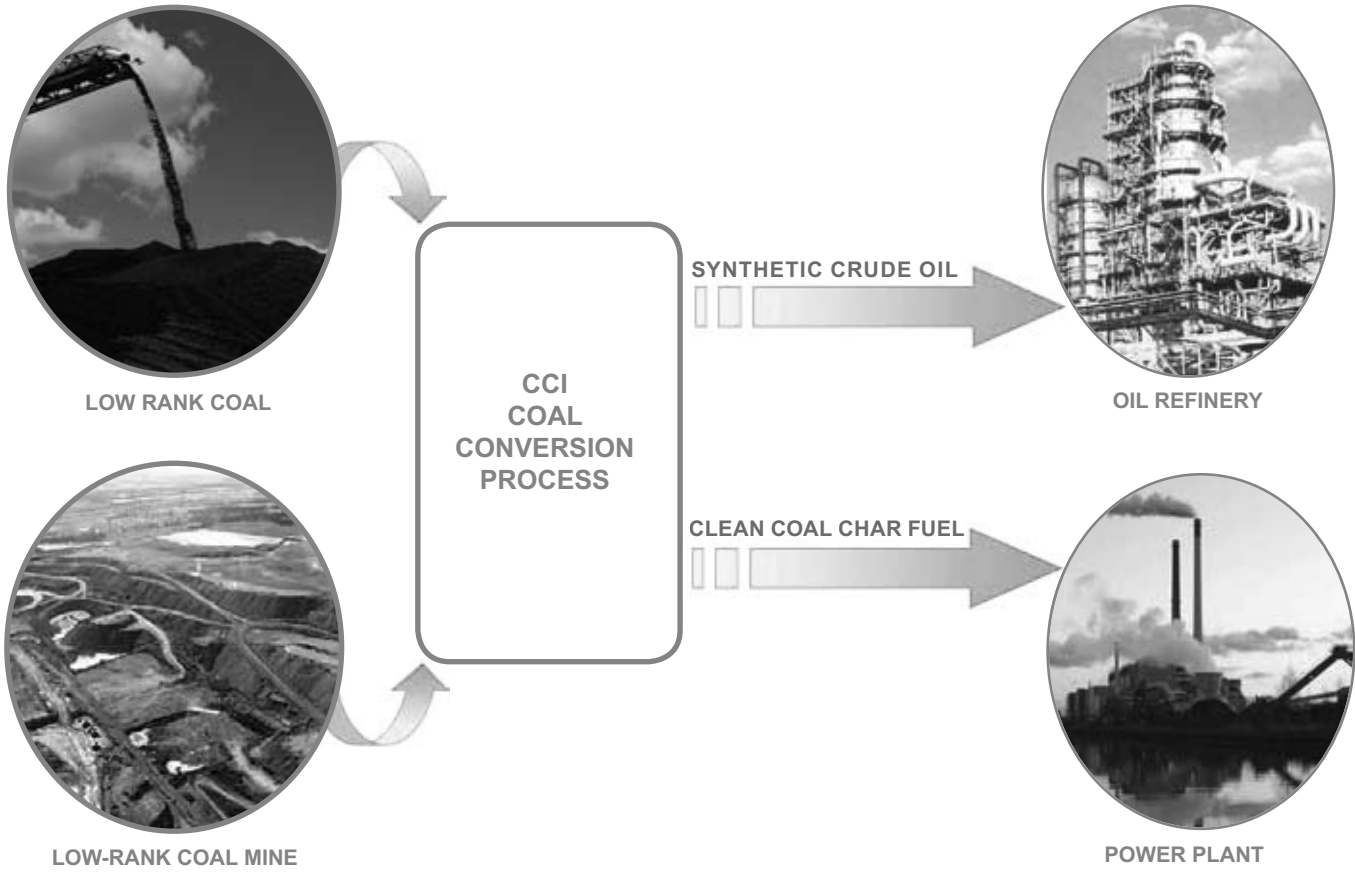

ConvertCoal, Inc.  
 4207 Belclaire Avenue, Dallas TX 75205  
 Phone: 214-521-6055 | Fax: 214-526-3398 | Email: Info@ConvertCoal.com  
 www.ConvertCoal.com

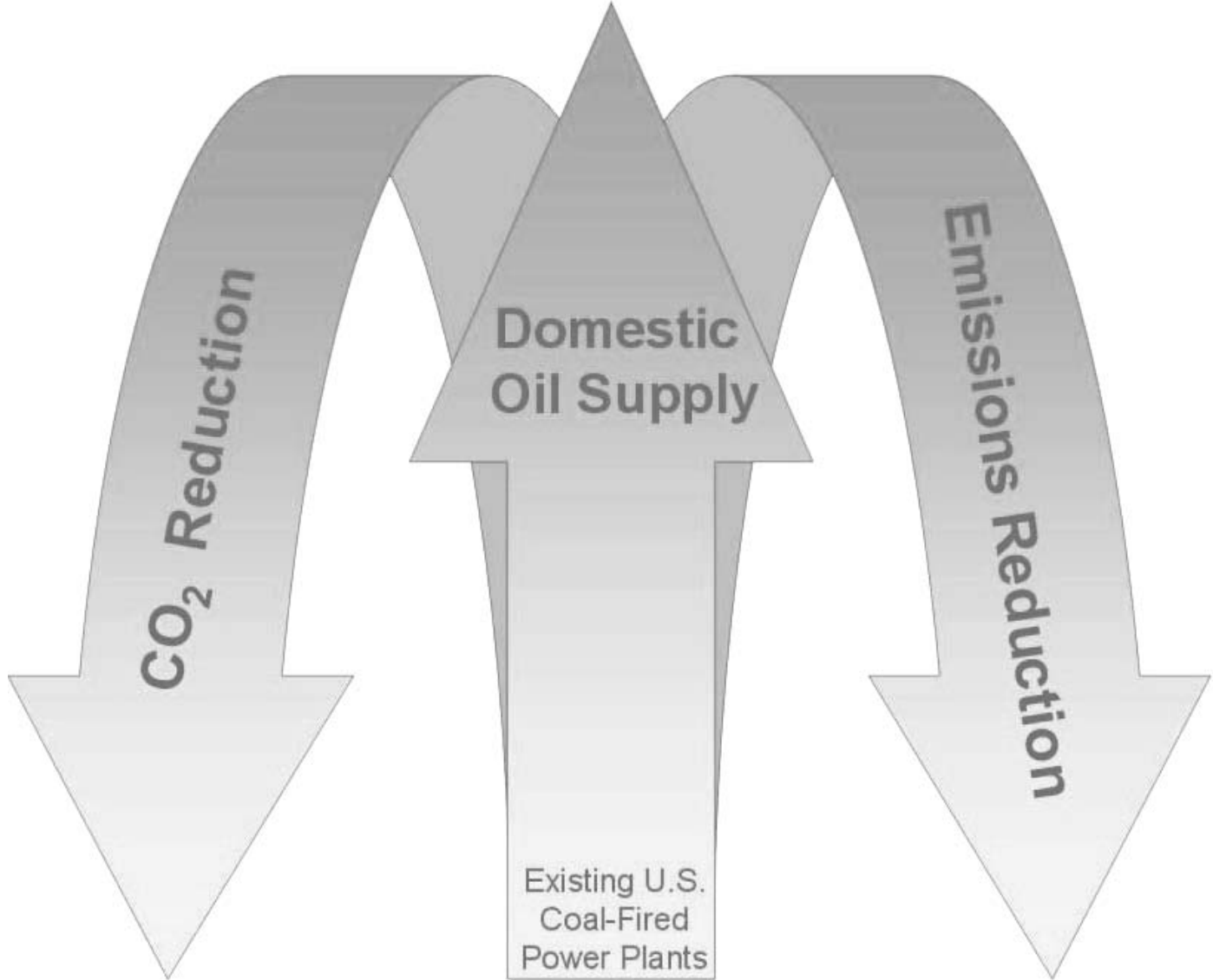

**CONVERTCOAL, INC. INTRODUCTION**

ConvertCoal, Inc., a Texas corporation, was founded in 2005. ConvertCoal, Inc. (CCI) has developed a continuous process for converting lignite and sub-bituminous low-rank coal (LRC) in part into a Synthetic Crude Oil (SCO) suitable for petroleum refining, and in part into low-emission coal-char fuel (CCF) for power generation and iron ore reduction (Fig-1). CCI's proprietary coal conversion process technology embodies significant advancements over prior technology with regard to oil recovery yield and quality, process operability and capital cost. CCI provides process licenses and technical assistance and services to project developers.

**NEW DOMESTIC OIL SUPPLY**

CCI coal conversion projects will be located adjacent to electric generating power plants of a 500 megawatt capacity or larger (Fig-2). Such projects will convert approximately 10,000 tons per day of lignite or sub-bituminous coal, producing 7,000 barrels per day or more of synthetic crude oil, 500 gallons per minute of clean water, and sufficient upgraded clean-coal char fuel for the power generation plant. A new synthetic crude oil project will be the equivalent of a new oil field with 70 million barrels of recoverable oil-in-place over the 30-year horizon.

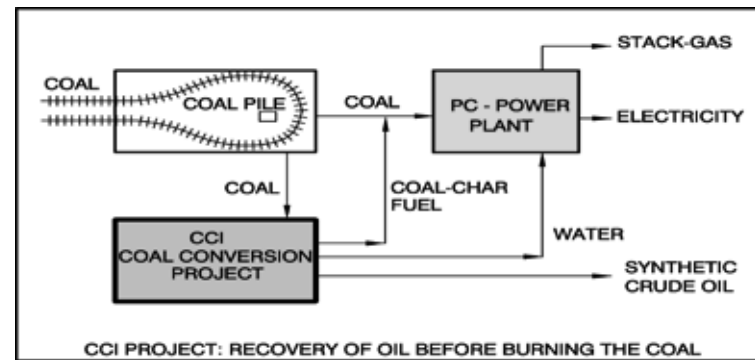

FIG-2

**COAL CONTAINS RECOVERABLE OIL**

Coal contains 0.5 to 1.0 barrel of directly recoverable oil per ton of coal. Recovering this oil before the coal is burned increases its value from coal to oil. Coal is currently used for generating more than half of the electric power in the U.S. and therefore can become an important domestic oil resource. CCI provides a process technology for extracting oil from lignite and sub-bituminous coals that comprise 75% of coal mined domestically (Fig-3). The CCI process upgrades the feed-coal into a higher efficiency coal-char fuel product with lower emissions, and coal-tar-oil that is processed into added value synthetic crude oil.



FIG-3

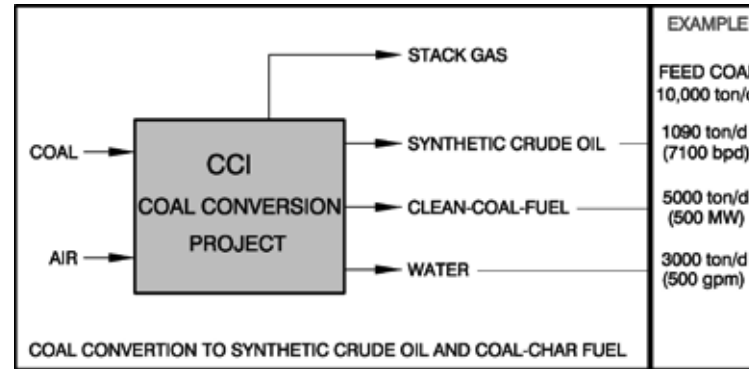

FIG-1

**SYNTHETIC CRUDE OIL PRODUCT**

The synthetic crude oil (SCO) is obtained after hydroprocessing of the coal-tar-oil that is recovered from the coal pyrolysis process. SCO is similar to low-sulfur West Texas Intermediate crude oil, but with higher aromatics content akin to Alaska North Slope crude oil. The SCO product composition and yield vary somewhat with the feed-coal quality and operating conditions. Based on a typical Western U.S. low-sulfur sub-bituminous coal from the Powder River Basin, Wyoming, the SCO product will be about 30 API Gravity (0.975 g/ml), 60w% aromatics, less than 7w% fraction with boiling point above 440 C° (824° F), and less than 0.1w% sulfur, and 0.2w% nitrogen.

**COAL-CHAR FUEL PRODUCT**

The clean coal-char fuel (CCF) product remaining after oil recovery is an upgraded fuel suitable for power generation and iron ore reduction, with substantively lower emissions, higher heating value and higher efficiency than the feed-coal. The CCF product, after processing and removal of water, gas and coal-tar oil, has 40% to 50% increased heating value and 5% to 10% higher power boiler efficiency, 35° C higher flame temperature and significantly less sulfur, nitrogen and mercury. CCF produced from an average low-sulfur Western U.S. LRC meets the U.S. EPA 2010 CAIR regulations for emissions without additional mitigation. The CCF fuel efficiency increase translates directly into lower fuel demand, lower CO<sub>2</sub> emissions, savings in captive power demand, and potential capacity recapture for power plants that have been de-rated due to an earlier change to LRC. CCF also can become a lower cost fuel alternative to metallurgical coke in direct iron ore reduction.

**ENERGY TRANSITION PERIOD**

Increasing awareness of the limits to available oil resources worldwide has brought into focus the need for an energy transition period, during which sustainable alternative energy supplies can be phased in without devastating economic disruptions. There are important reasons why the CCI process is an appropriate energy conversion technology for the 40-year energy transition period as the world adjusts from reliance on fossil fuels to renewable, alternative energy resources. First, the CCI process can provide synthetic crude oil from abundantly available domestic coal. Second, it simultaneously converts two-thirds of the coal into higher efficiency, low-emission coal-char fuel. Third, the coal conversion process is environmentally sound, and economically attractive at current energy prices. Therefore, during the energy transition period it can add significantly to the domestic crude oil supply, increase the efficiency of power generation, eliminate and significantly reduce greenhouse gas emissions, and provide substantial domestic economic activity based on abundant domestic coal resources.

**CCI TECHNICAL SERVICES**

CCI will provide the process license and basic process design package for its coal conversion technology. In addition, CCI will provide technical oversight during the engineering, procurement, construction, and start-up phases of the project. CCI also provides consulting services, feasibility studies, process engineering studies, economic evaluations, and related services for energy development projects. Major energy projects apply a phased approach to project development, starting with a Phase I, Conceptual Project Feasibility Study for initial identification and evaluation of the project. When the project looks promising, a Phase II Project Feasibility Study will be developed based on site-specific project information, defined capacity, estimated capital cost, and identification of key issues, including environmental permitting, economic viability, feedstock supply, product acceptance, etc.

In addition, continuous-flow pilot plant testing can be performed for production of product samples and coal quality evaluation. The considerable variability of feed coal requires process evaluation and adaptation with respect to operability, temperature, profile, residence time, and product yields and qualities. For this purpose, CCI uses pilot plant and process unit demonstration equipment to evaluate process operating parameters of the critical key process sections (Fig-15). Such equipment includes dryers, pyrolyzers, hydrotreating reactors, and equipment suppliers' pilot demonstration units.

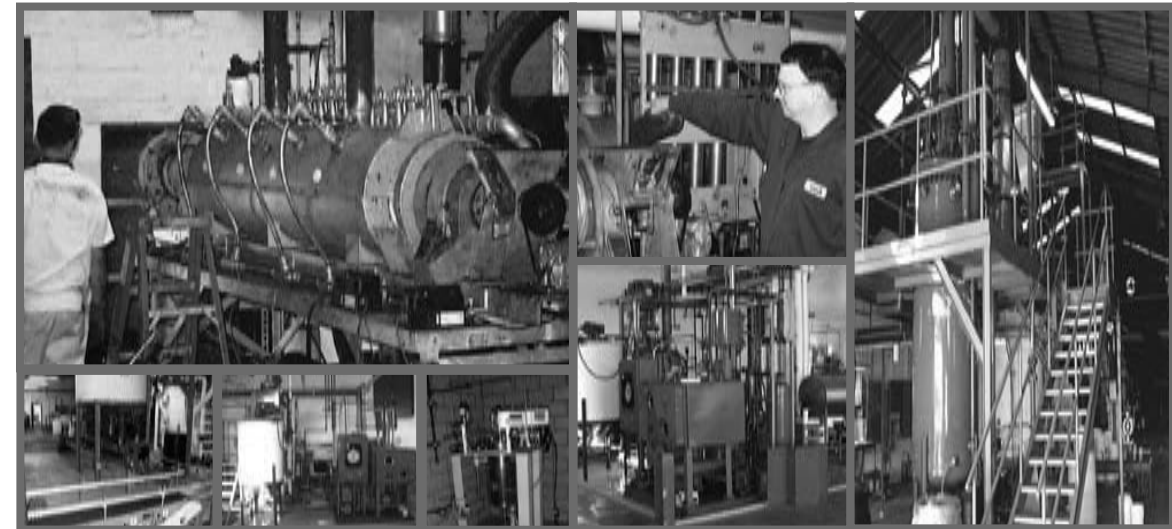

Pilot plant equipment for coal testing and process demonstration

FIG-15

**BASIS FOR CCI COAL CONVERSION TO OIL**

In summary, there are five principal elements supporting the economic extraction of oil from coal:

- Coal generally contains 15% to 25% extractable oil that can be recovered before the remaining coal-char fuel is burned in power-generating plants.
- The extracted coal-tar oil can be converted via catalytic hydrogenation into refinery-grade synthetic crude oil (SCO).
- The remaining clean coal-char fuel has less than one third of the emissions due to the removal of mercury, sulfur and nitrogen compounds. In addition, because it has 5 to 10% higher fuel efficiency due to the removal of water, the direct savings in fuel and CO<sub>2</sub> emissions will be up to 10% depending on the coal composition.
- Large industrial-scale continuous process technology has been demonstrated in operation at up to 1,000-tons per day. During the five-year demonstration project, a dozen coals were processed, and the clean coal-char fuel was tested successfully at 7 power plants.
- The abundance of lignite and sub-bituminous coals can provide long-term domestic supply security for coal-power generation and production of SCO. Oil production can be substantial since 500-MW coal-power generation provides a basis for 7,000-barrels or more per day of oil.

**CCI PROCESS CARBON FOOTPRINT**

The CCI process can potentially be “carbon neutral” due to the high coal-char fuel (CCF) energy efficiency and the high coal-to-oil conversion efficiency. In addition, the relatively high CO<sub>2</sub> concentration in the process gas makes it easier for future carbon capture and sequestration. A power plant using CCF fuel will reduce CO<sub>2</sub> emissions by 6% to 14% depending on feed-coal composition as a result of removal of moisture, pyrolysis water and inert gas from the coal, and the increased heating value of the fuel (Fig-13). The CCI plant generates CO<sub>2</sub> in several of the process sections, including pyrolysis and hydrogen production; however, the CO<sub>2</sub> in the process gas streams is more concentrated than in power plant stack gas and therefore less expensive to capture.

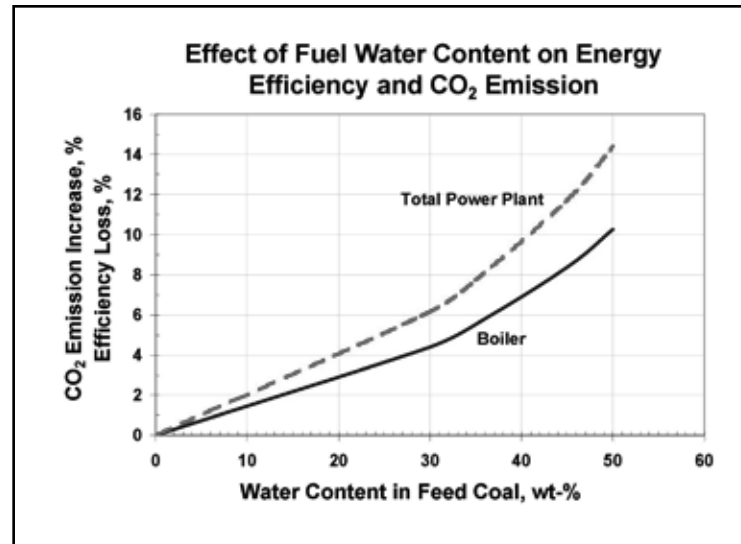

FIG-13

**CCI PROJECT ECONOMICS**

The economic viability of CCI projects is similar in capital cost and conversion costs per barrel of oil to “unconventional oil” projects such as oil-sands, deep-ocean oilfields, and bituminous heavy-oil projects. At current oil and coal prices, the value of the recovered synthetic crude oil will be three quarters or more of the total value of energy products sold from a CCI project (Fig-14). The energy balance shows that two thirds of the incoming coal is converted to coal-char fuel, approximately one quarter to oil and the balance to pyrolysis gas. An example based on sub-bituminous coal shows a mass balance with approximately 49% coal-char fuel, 12% oil, 7% fuel gas, and 32% water (Fig-14). The dominant economic factor for the CCI coal conversion projects is the value of the synthetic crude oil product, followed by capital cost and cost of feed coal. Above \$45 per barrel, attractive returns on investment can be obtained; however, in each individual project, the capital cost, coal quality and cost, and oil yield require careful evaluation.

**CCI PROJECT ECONOMIC ACTIVITY**

In economic terms, ten nominal 7,000-bpd coal conversion projects will save \$2-billion annually in crude oil imports based on, for example \$75 per barrel, or \$50-billion over a nominal 30-year project life, at a capital cost of \$5-billion. A single 7,000-bpd oil project will generate significant local economic activity, including an estimated annual \$20 million for local subcontracting and payroll for 120 full-time employees, and a substantial amount of local taxes associated with the \$500-million capital project. In addition, the indirect local economic activity generated from such major energy projects will be about seven times the direct industry payroll. Equally important, energy projects based on domestic resources provide secure jobs for the long term and help improve the nation’s economic security.

**MASS, ENERGY AND PRODUCT VALUES**

Coal Mass Balance

Coal Energy Balance

Relative Product Value

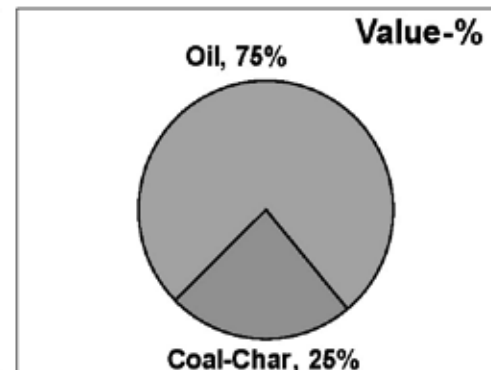
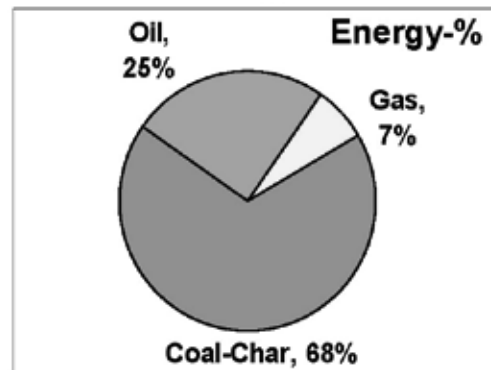
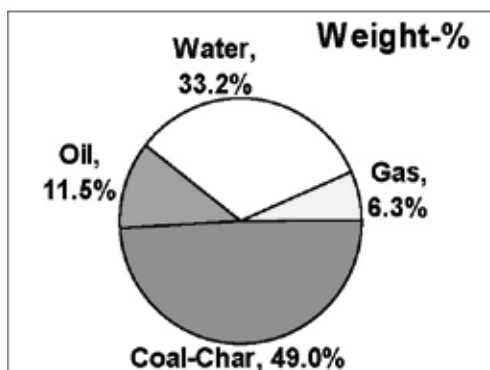

Example: RPD-01, Sub-bituminous coal, Powder River Basin, Wyoming; Coal-Char \$42/ton, Oil %75/bbl

FIG-14

**CCI COAL CONVERSION PROCESS**

The proprietary CCI third-generation process is a unique, continuous, large industrial scale process for converting LRCs to synthetic crude oil (SCO) and clean-coal fuel (CCF). The primary processes are coal drying, pyrolysis, coal-tar oil recovery and conversion of recovered coal-tar oil into SCO. Lignite and sub-bituminous coal contain 25 - 50w% water, 5 to 15% ash and 30 to 40w% “volatile matter,” i.e., coal-gas and coal-tar oil volatilized up to 900° C (1650° F) (Fig-4). The CCI Rinker-England-Skov (RES) coal conversion process is comprised of several large-scale, continuous process operations that convert lignite and sub-bituminous coal into an oil fraction and high-efficiency, low-emissions CCF. The RES process has three unique sections for pyrolysis, oil recovery, and oil conversion into SCO. The pyrolysis process removes water and impurities from the feed coal, increasing the heating value by 40% or more. This in turn increases coal-boiler efficiency by up to 10% and reduces CO<sub>2</sub> emissions by the same amount. In addition, emission of SO<sub>2</sub> is decreased by up to 70% and mercury up to 90%. The volatilized gas is cleaned for use as fuel and the coal-tar oil is condensed and hydrotreated to produce SCO.

**IMPORTANT PROCESS FEATURES**

In terms of commercial viability, the four most important features of the RES coal conversion process are:

- It is a continuous pyrolysis process designed for low-rank coal and large industrial plant capacity in the range of 10,000-tpd coal range, 7,000-bpd oil, and 500 MW (Fig-5).
- The coal-tar oil recovery process provides an increased oil yield provides and a viable basis for economic project development (Fig-6).
- The process includes integrated hydroprocessing for conversion of the coal-tar-oil to refinery-grade synthetic crude oil (Fig-7).
- To reduce the project risk, the process employs industrial equipment that is presently in commercial service.

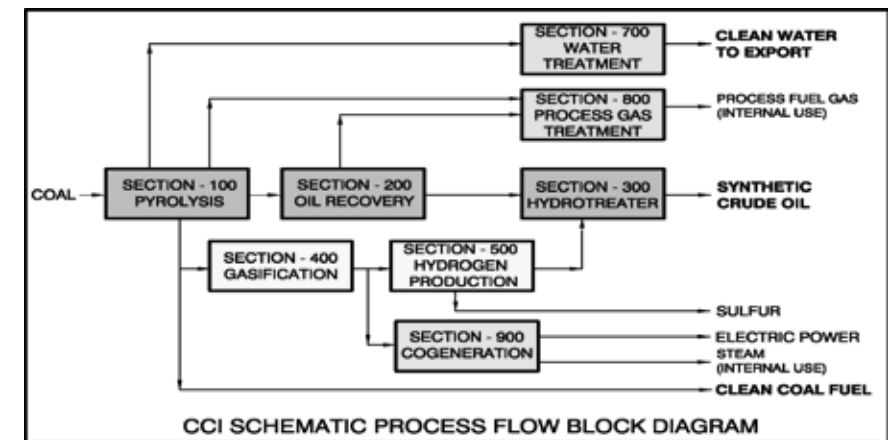

FIG-4

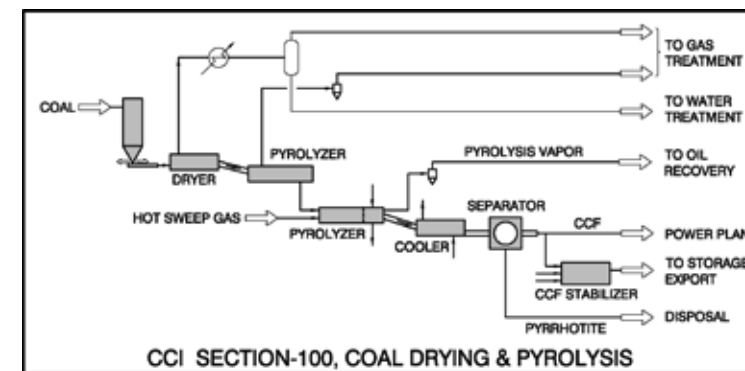

FIG-5

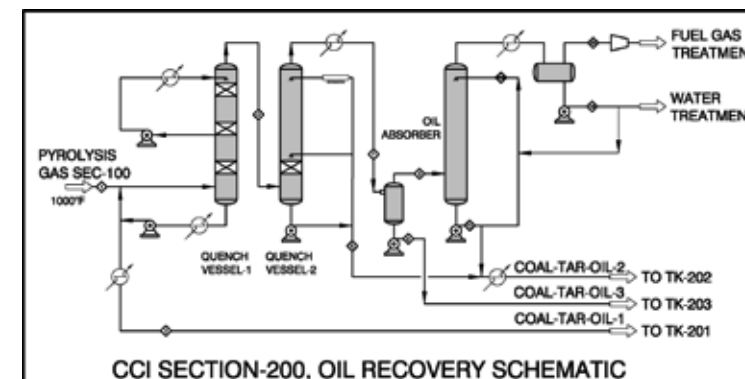

FIG-6

**COAL CONVERSION EFFICIENCY**

The energy efficiency of the CCI coal conversion to synthetic crude oil is approximately 70%. This is substantially better than other coal-to-liquid processes such as coal gasification followed with Fischer-Tropsch synthesis of gas-oil, methanol or mixed alcohol, which all appear to be about 50% efficient. The higher energy conversion efficiency of the CCI process results from recovering only the lowest boiling two-thirds of the oil present in the coal. Importantly, sufficient volatile matter is allowed to remain in the processed coal-char to qualify it as a superior fuel for power boilers and iron ore reduction.

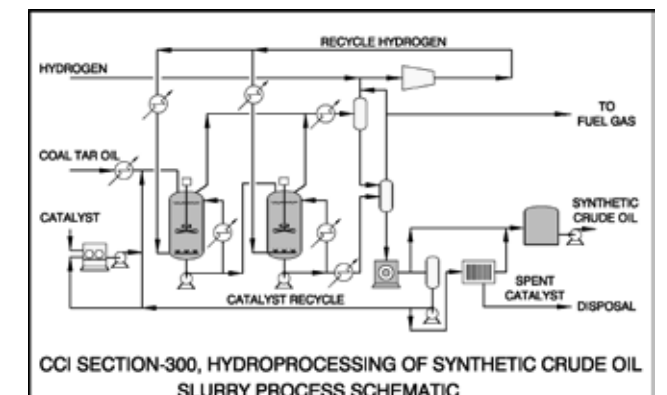

FIG-7

**CCI PROCESS TECHNOLOGY DEVELOPMENT MILESTONES**

Important precursors for the third-generation CCI continuous coal pyrolysis process include the first-generation German coal conversion technology, the second-generation “Toscoal process” using indirect pebble-heating, and notably the ENCOAL 1992 – 1997 U.S. DOE-SGI/Shell Mining Corp., 1000 ton per day demonstration project (Fig-10). The ENCOAL project provided large-scale proof-of-process using a dozen different low-rank feed-coals during five years, and demonstrated the clean-coal-char fuel quality and operability in seven power boilers.

Starting in 2005, CCI assembled a uniquely experienced engineering team for the development of an advanced process and project design strategy, optimizing energy use and project capital cost. This work resulted in the proprietary Rinker-England-Skov (RES) Process. CCI has presented the new process at several international coal and energy technology conferences, including the Pittsburgh Coal Conference and Western Fuels Conference in 2006, the National AIChE Conference in Houston, and the Freiberg CTL Conference in Germany in 2007, and the Electric Utility Environmental Conference in 2008. CCI completed a reference plant design, RPD-01, and prepared a capital cost estimate for a 10,000-tpd LRC project in 2008.

**CCI PROCESS MATURITY**

The CCI project is ready for large commercial-scale project development based on successful demonstration plant operations. To reduce project risk, the CCI project design uses commercially available equipment and engineering design based on the standards and specifications used in the minerals processing and oil refining industries. In addition, each individual process step can be demonstrated separately, as required. Considering the differences between coal compositions, each individual project will require testing of the selected feed-coal. This will include laboratory assays and processing evaluations in continuous-flow pilot plant equipment, and large-scale performance testing by the equipment supplier as a basis for obtaining performance guarantees.

**CCI REFERENCE PLANT DESIGN**

The CCI reference plant design, RPD-01 was designed in 2007 to match the supply of clean coal char fuel (CCF) for a nominal 500-MW capacity pulverized coal power generating plant (Fig-8 and -9). The design feed-coal is sub-bituminous coal from Wyoming Powder River Basin previously tested in the DOE demonstration project, containing 29w% water, 6w% ash, 0.8w% sulfur and HHV 8,400-Btu/lb (19.5 MJ/kg). The nominal project capacity is 10,000 tpd feed-coal, 5,000 tpd clean CCF (11,400 Btu/lb, 26.5 MJ/kg), 7,100 barrels per day synthetic crude oil, and 3,000 tpd process water (500-GPM). Site-specific projects can be designed for a range of feed-coal qualities and oil-to-CCF ratios.

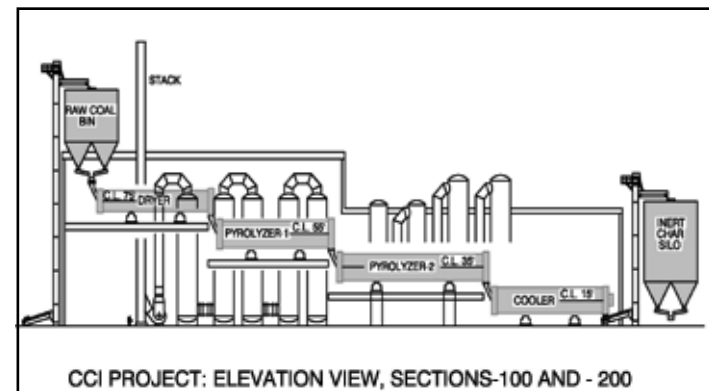

FIG-8

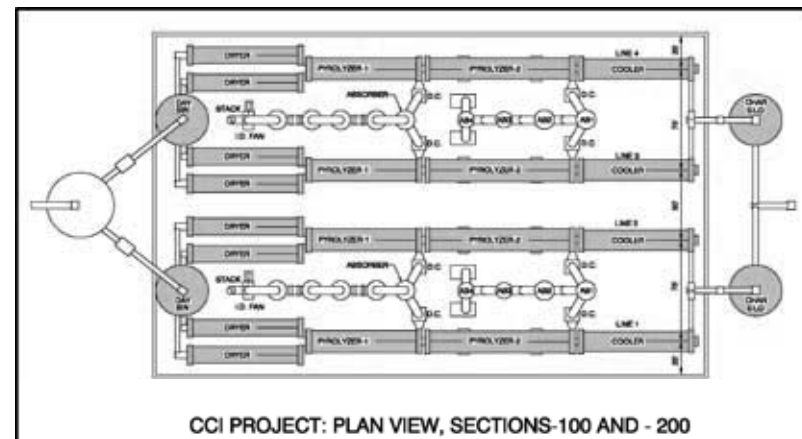

FIG-9

**COAL CONVERSION PROCESS APPLICATIONS**

The RES Process is applicable to lignite and sub-bituminous coals, collectively called LRCs, that comprise more than two thirds of all coal resources in the U.S. and worldwide. U.S. production of LRC exceeds 750-million tons per year or two-thirds of the coal used for electric power generation. Worldwide, large LRC resources are underutilized due to excessive water content and transportation cost. The application of the RES Process will increase the use and value of these important energy resources, turning LRC into a valuable domestic oil resource while simultaneously upgrading it to clean CCF for power generation and for use in certain metallurgical applications.



ENCOAL Demonstration Project 1,000 tons per day U.S. Department of Energy/SGI/SMC, Gillette, Wyoming 1992 - 1997 FIG-10

**LOW PROJECT BUSINESS RISK**

The business risks of a CCI project compare favorably with the risks associated with the development of a new 7,000-bpd oilfield. The CCI project can be defined with predictable capacity, capital cost, construction schedule, and operating and maintenance cost. This is not the case with many oilfield exploration and development projects. CCI oil production will be predictable without declining over time, and CCI projects will not have geology or off-shore project risks.



Open Pit mining of Low-Rank Coal, Wyoming, U.S.A. FIG-11

**CCI SCOPE OF DOMESTIC OIL SUPPLY**

The 2008 domestic U.S. oil reserve was 21-billion barrels of recoverable oil, with an average production of 5.7-million barrels per day, according to the U.S. Energy Information Agency. For CCI, the potential domestic U.S. scope of synthetic crude oil (SCO) production is 1.9 million barrels per day based on CCI coal processing for the existing low-rank coal power generating plants (Fig-11). This potential oil production equals a third of current domestic oil production and a tenth of current consumption. And the equivalent 30-year resource of “recoverable SCO in place” would be 20-billion barrels. These estimates are based on the current 150,000 MW power generating capacity using low rank coal, 10,000 Btu per kWh, a nominal 16.8-million Btu per ton coal, and a total of 2.7-million tons coal per day, including the coal required for the additional production of SCO.

Countries with large coal resources and major coal-power generating capacity, providing a basis for development of a significant SCO production, include Australia, China, India, and Indonesia.

Major energy supply projects are capital intensive. According to the International Energy Agency, 2008 World Energy Outlook IEA Oil Report: Time is Running Out, “The world will need to invest half a trillion dollars per year for the next 22 years just to maintain current supply levels of oil.” In this perspective, just one percent of this budget would provide 10 CCI projects equivalent to the discovery of a major new 70,000 bpd oil field annually (Fig-12).



Conventional Oilwell Development FIG-12